

# FLY KNIFE IDENTIFICATION



**ZENITH CUTTER**  
A FISHER BARTON COMPANY

**WHEN IT'S MAKE OR BREAK.™**

5200 Zenith Parkway • Loves Park, IL 61111  
Tel: (800) 223-5202 • [www.zenithcutter.com](http://www.zenithcutter.com)

QUOTE NUMBER: \_\_\_\_\_

MACHINE NAME: \_\_\_\_\_

MACHINE MODEL: \_\_\_\_\_

OEM# (if available): \_\_\_\_\_

1.) Note any part numbers or markings on the knife:  
\_\_\_\_\_

Please complete the following information:

A. Height: \_\_\_\_\_

B. Length: \_\_\_\_\_

C. Thickness: \_\_\_\_\_

2.) Hole/Slot information:

Type of holes: \_\_\_\_\_

D. Quantity of holes: \_\_\_\_\_

E. Hole diameter: \_\_\_\_\_

F. C'bore/C'sink diameter: \_\_\_\_\_

G. Bottom edge to hole/slot edge: \_\_\_\_\_

H. End to first hole/slot edge: \_\_\_\_\_

I. Typical hole/slot spacing: \_\_\_\_\_

J. C'bore/C'sink depth: \_\_\_\_\_

3.) Taper angle (if applies):

K. Taper angle: \_\_\_\_\_

L. Bevel angle (1): \_\_\_\_\_

M. Bevel angle (2): \_\_\_\_\_

N. Horizontal bevel point: \_\_\_\_\_

4) Note any special features:  
\_\_\_\_\_

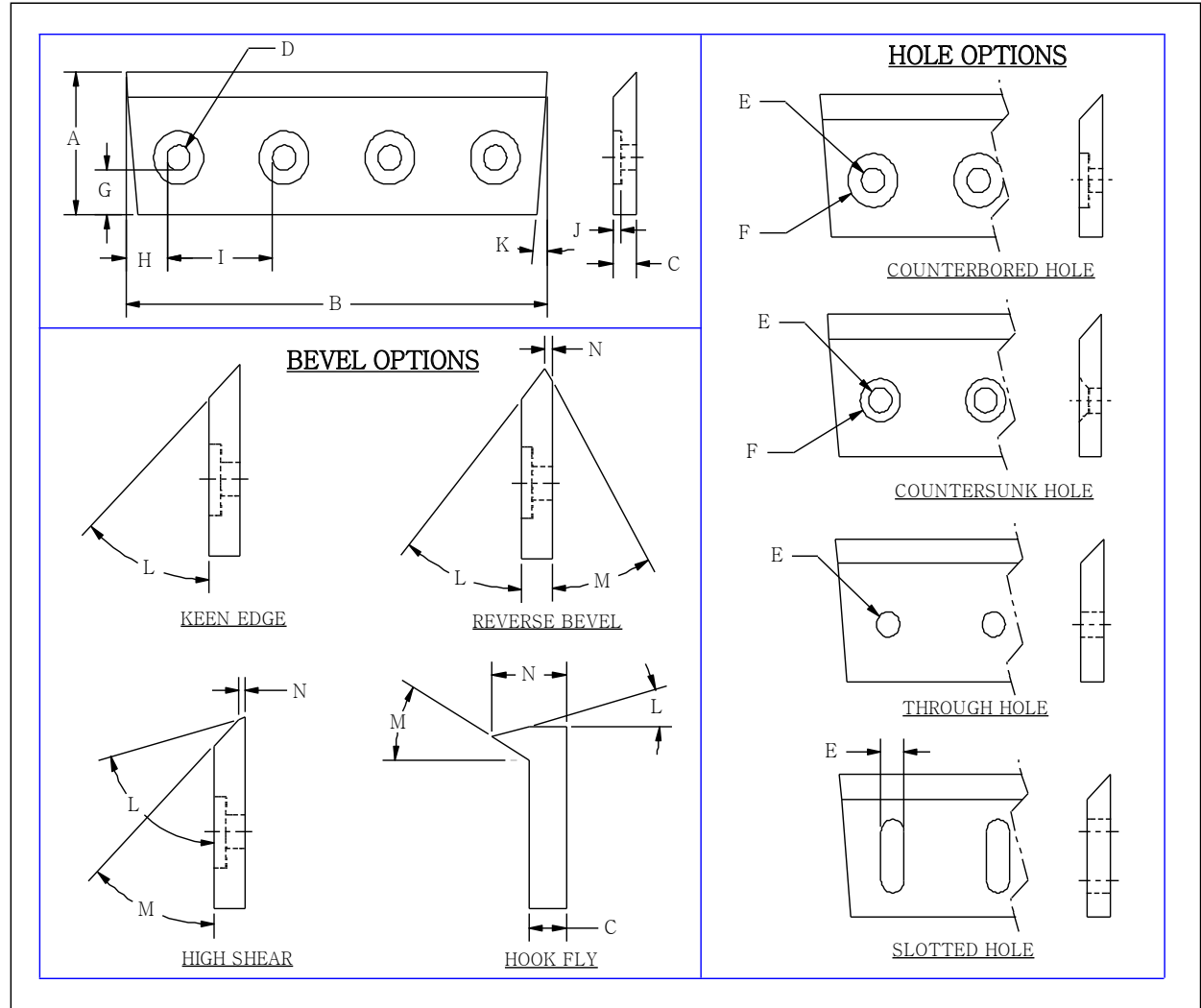

**How to use this form:**

Please fill out this form to help us identify your fly knife. Once completed, please send this form to [sales@zenithcutter.com](mailto:sales@zenithcutter.com) or to your Zenith Cutter sales representative.